



## Physical Characteristics:

### Dimensions:

Profile: 20x25mm H

See diameters on next page

### Diffuser Options:

Matt opal frosted

### Mounting Options:

- Suspended 6 x wire 3000mm (one acts as power supply) back to canopy (BTC)  
Canopy Size: 240mm Ø x 50mm H
- Suspended 6 x wire 3000mm (one acts as power supply) direct to ceiling (DTC)  
No Canopy

## Electrical Configuration:

### Power:

- 450/600mm = 60 Watts
- 600/800mm = 78 Watts
- 800/1000mm = 102 Watts
- 1000/1200mm = 125 Watts
- 1200/1500mm = 137 Watts

### IP Rating:

IP20

### Lumen Efficacy:

>80 Lumens / watt

### LED Lifetime:

50,000 Hours @ 25°C

### Control Gear:

Constant current LED Driver

### Dimming Options:

Phase cut included (up to 600/800mm only)

1-10 Volt included (800/1000mm +)

SwitchDIM optional

DALI optional

## Photometric's:

### Lumen Output:

- 60 Watts = 4410 lumens
- 78 Watts = 5644 lumens
- 102 Watts = 6284 lumens
- 125 Watts = 7300 lumens
- 137 Watts = 9100 lumens

### LED Type:

Samsung LED boards

### CRI:

CRI 80+

### CCT:

3000k, 4000k, 5000k

*(Outputs based on 3000k)*

### Distribution:

Direct. 120° Diffused.

*(Indirect light output available)*

## Finishes:



Texture Black



Texture White



Brushed Gold  
*(450, 600 & 800mm only)*



Brushed Nickel



Tarnished Brass  
*(Indent line)*



Custom Colour  
*(Select your own)*

Size options:

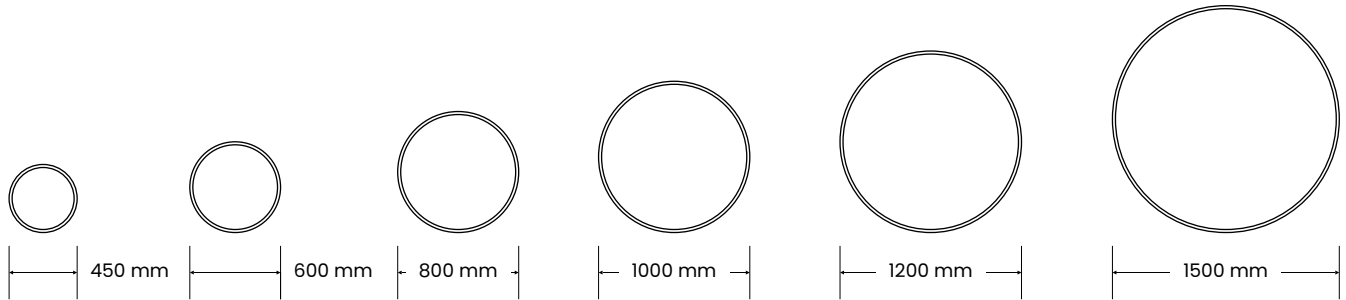

*(All diameters can be combined to create tiered pendants)*